

Schlumpf Ergonomic Handling Systems



- Low Cost
- Modular Design
- Simple Function
- Made In U.S.A.
- Safe, Easy and Economical



Shown with 3" LC Mandrel

**LIFT · TURN · TRANSPORT · LOAD · UNLOAD
· STACK · STORE · PACKAGE · PALLETIZE**



Shown with 3" LC Mandrel

Schlumpf's **MRT-100** is a hoist based mechanical roll turner engineered to assist operators in efficiently lifting and turning rolls with weights to 100 lbs (45 kg). The unit features our quick change tooling design that accepts light capacity mandrels for grabbing rolls by the core. Holding the roll by the core eliminates the need to contact the rolled material keeping it cleaner and preventing damage.

Most often used to handle light weight rolls of sensitive material, the **MRT-100's** amazing turning function enables operators to turn loads with minimal effort and no external power source. Supplied with a movable hoist point mechanism the **MRT-100** can quickly be adjusted for varying roll widths to ensure exact horizontal and vertical positioning. Rolls can be turned as quickly as the operator can move making for safe, rapid handling of your valuable product. By removing the need to "Manhandle" repetitive loads the **MRT-100** reduces the risk of operator injury while keeping your valuable product safe from damage, making your work place safer, increasing productivity and saving you money.

"Back Injuries - Nations Number One Workplace Safety Problem." The U.S. Department of Labor reports that more than one million workers suffer back injuries in the U.S. each year, costing industry billions of dollars on top of the pain and suffering borne by employees. Schlumpf Ergonomic Handling Systems will minimize or eliminate the risk of operator injury and maximize productivity and profits.

MRT-100 Manual Roll Turner

Standard Features:

- Fast and easy to use for all operators and skill levels.
- Simple center-of-gravity adjustment
- Ergonomic design with comfortable handles.
- Quick-change expanding mandrel holder.
- Change mandrel sizes in seconds without tools.
- Lightweight aluminum design with hard-coated anodized finish.
- Simple, low maintenance design.
- Low on going operating costs.
- Modular design.
- Made in U.S.A.

Specifications:

- Maximum load capacity: 100 lbs (45 kg)
- Roll width for minimum turning resistance 12" (305 mm)
- Maximum roll width 16" (406 mm)
- Maximum roll diameter 34" (864 mm)
- Center-of-gravity adjustment 12" (305 mm)
- Machine weight: 20 lbs (9.1 kg)
- Shipping weight: 25 lbs (11.36 kg)
- Shipping dimensions: 24" (610 mm) W x 24" (610 mm) D x 18" (460 mm) H

Options & Accessories:

- Expanding mandrels 3" (76 mm).
- Pneumatic mandrel retract with switching.
- Bumper retract for roll loading and unloading.
- Core stops and extended mandrels.
- Extended turner for roll widths greater than 20" (500 mm).
- Integrated hoist controls.
- Mounting brackets for hoist pendants & controls.
- Custom configurations available.

Minimize Risk. Maximize Profits!

Distributed By:

Specifications and dimensions subject to changes without notice.
Consult Schlumpf for current drawings! Published 04-2005.



schlumpf

innovation. performance. quality.



*Upon Request

-Dimensions subject to change
 -Custom configurations available

The MRT-100 is a manual roll turner and has a maximum load rating of 100lb (45kg). Specific machine capacity is determined using the roll weight and dimensions for each application and may limit capacity to less than maximum load rating.

Roll Vertical Position

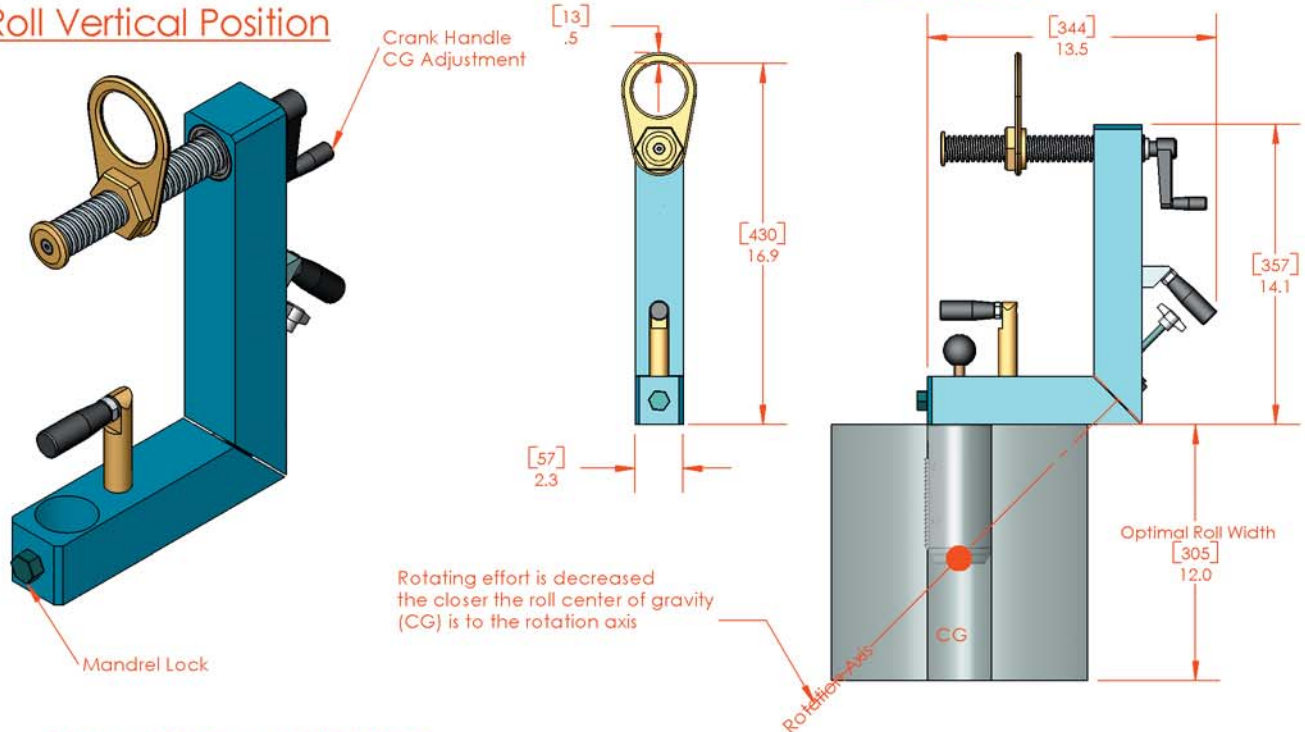

Roll Horizontal Position

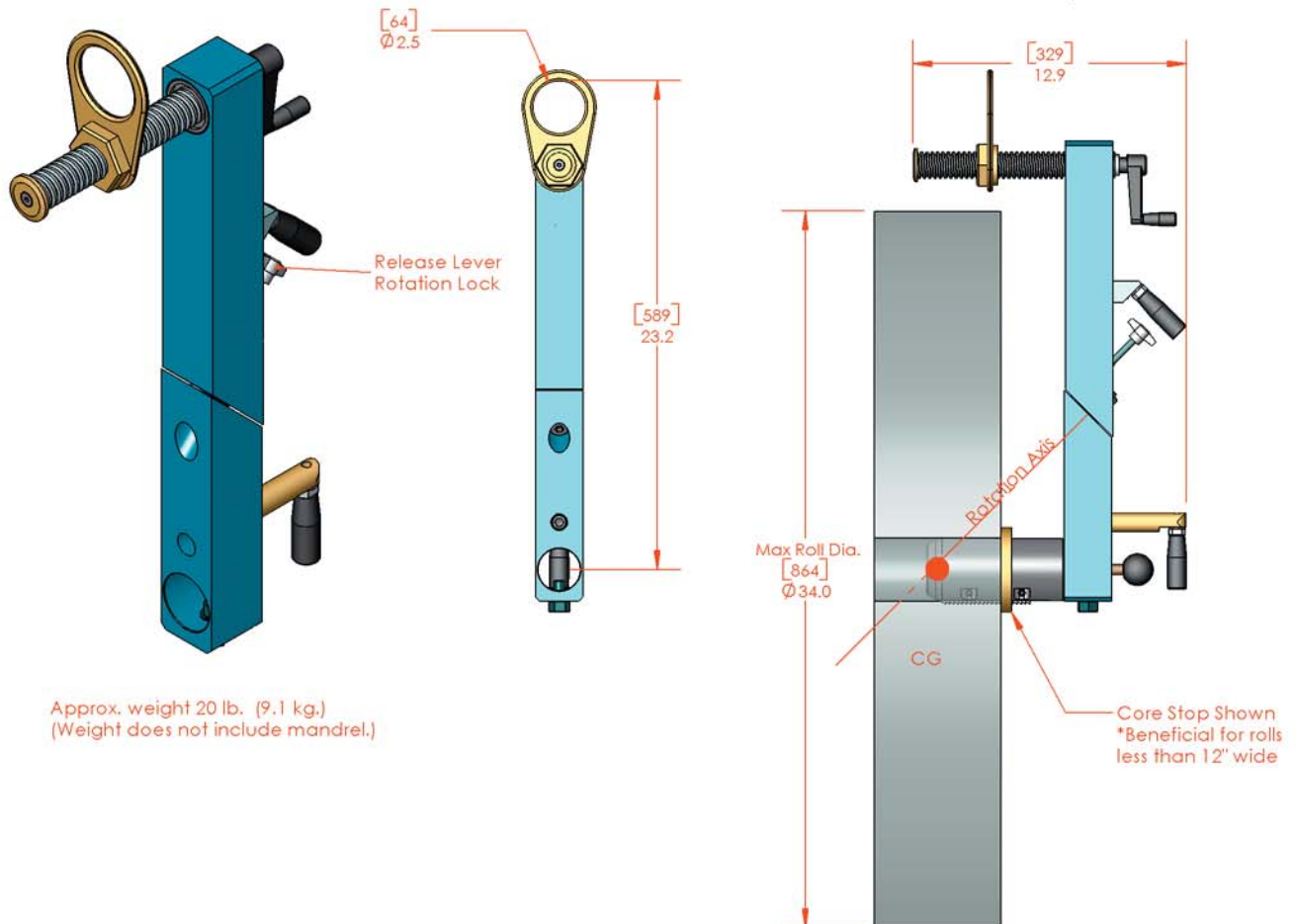

Approx. weight 20 lb. (9.1 kg.)
 (Weight does not include mandrel.)