

Universal Digital Load Cell Amplifier OWA200



The **OWECON OWA200 series amplifier** comes in three different versions for the customer to choose based on the need in the actual application.

The installation and calibration is very easy to do and due to the internal recognition feature the output automatically adjusts to the load cell input.

The internal filters give a steady display output and a balanced output signal, for easier handling of the actual data reading.

The OWA200 series is a universal digital amplifier designed to meet all requirements of tension sensing within industries that is handling printing applications, converting, paper, foil, narrow web, labels, ribbon, wire and other weight systems. The design does the amplifier able to handle all load cells known to us so far.

Design features:

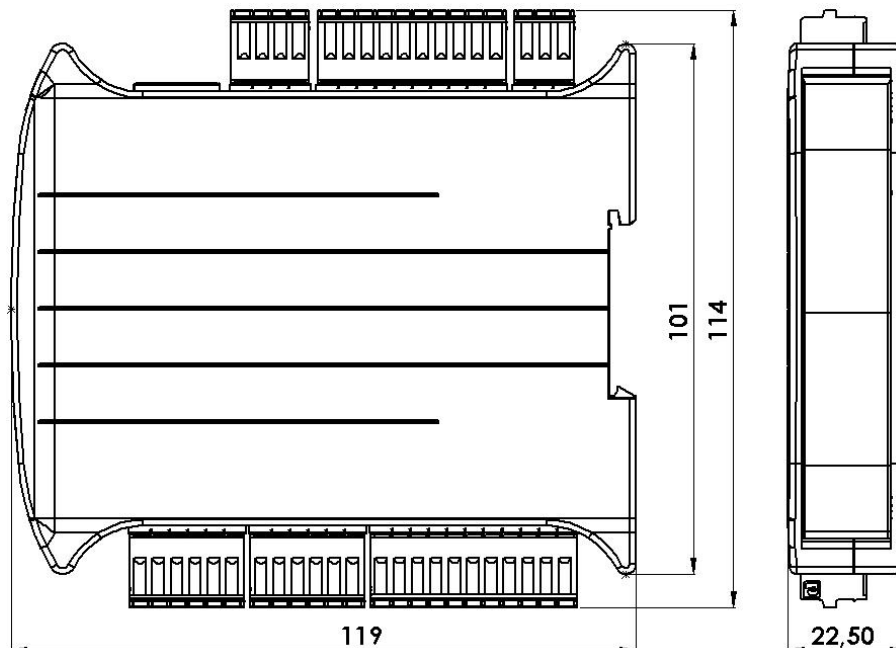

Input and output features for OWA210:

The OWA210 digital amplifier is designed for applications with 1 or 2 of semiconductor half bridge load cells and for 1 or 2 of foil gauge full bridge load cells. All load cell connection cables are mounted in one 6 pin plug screw terminal.

The power supply for the amplifier is 24V.

The output alternatives are 2 of 0-10V, 1 of $\pm 10V$ and 1 of 4-20mA

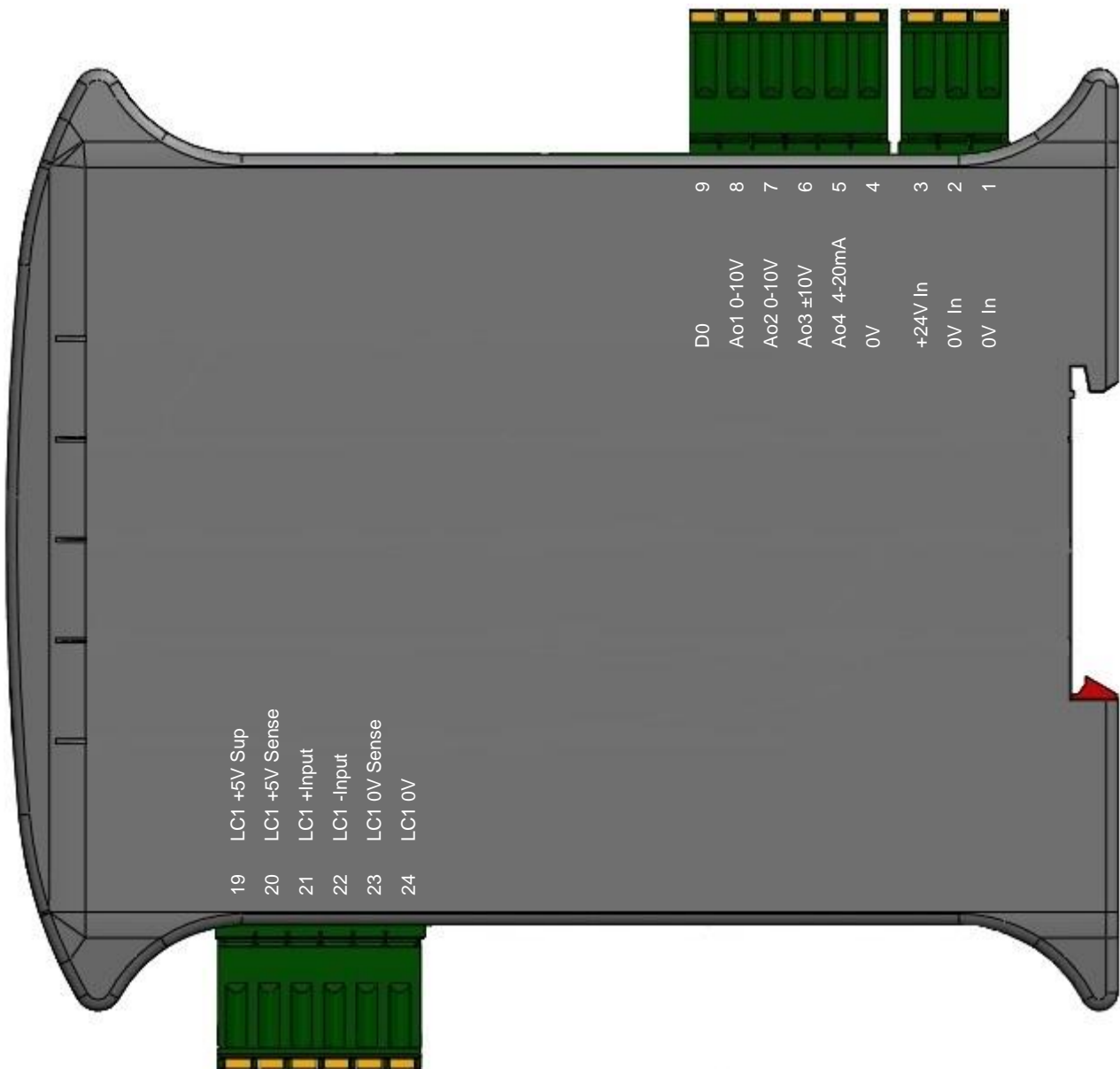

Input and output features for OWA220:

The OWA220 digital amplifier is designed for applications with 1 or 2 of semiconductor half bridge load cells and for 1 or 2 of foil gauge full bridge load cells. The load cell connection cables are mounted separately in each of the two 6 pin plug screw terminals. The separate mounting of the load cells makes it possible to have a “Total-Left-Right” measurement of the tension in the web. The power supply for the amplifier is 24V.

The output alternatives are 2 of 0-10V, 1 of $\pm 10V$ and 1 of 4-20mA.

For data communication the Modbus RTU/RS485 port is available.

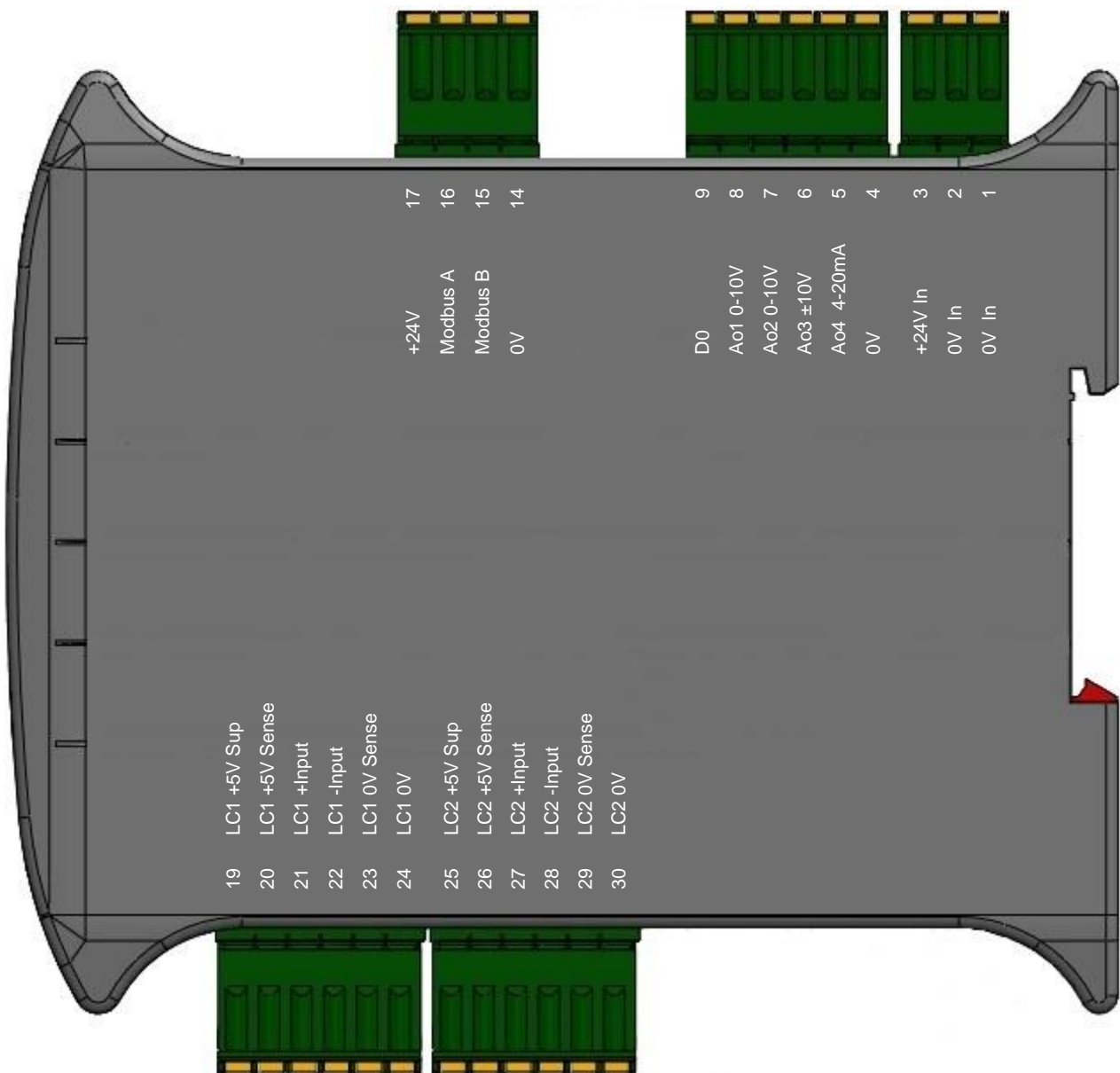

Input and output features for OWA230:

The OWA230 digital amplifier is designed for applications with 1 or 2 of semiconductor half bridge load cells and for 1 or 2 of foil gauge full bridge load cells. The load cell connection cables are mounted separately in each of the two 6 pin plug screw terminals. The separate mounting of the load cells makes it possible to have a “Total-Left-Right” measurement of the tension in the web. The power supply for the amplifier is 24V.

The output alternatives are 2 of 0-10V, 1 of $\pm 10V$ and 1 of 4-20mA.

For data communication the Modbus RTU/RS485 port and the Modbus TCP/IP Ethernet port is available.

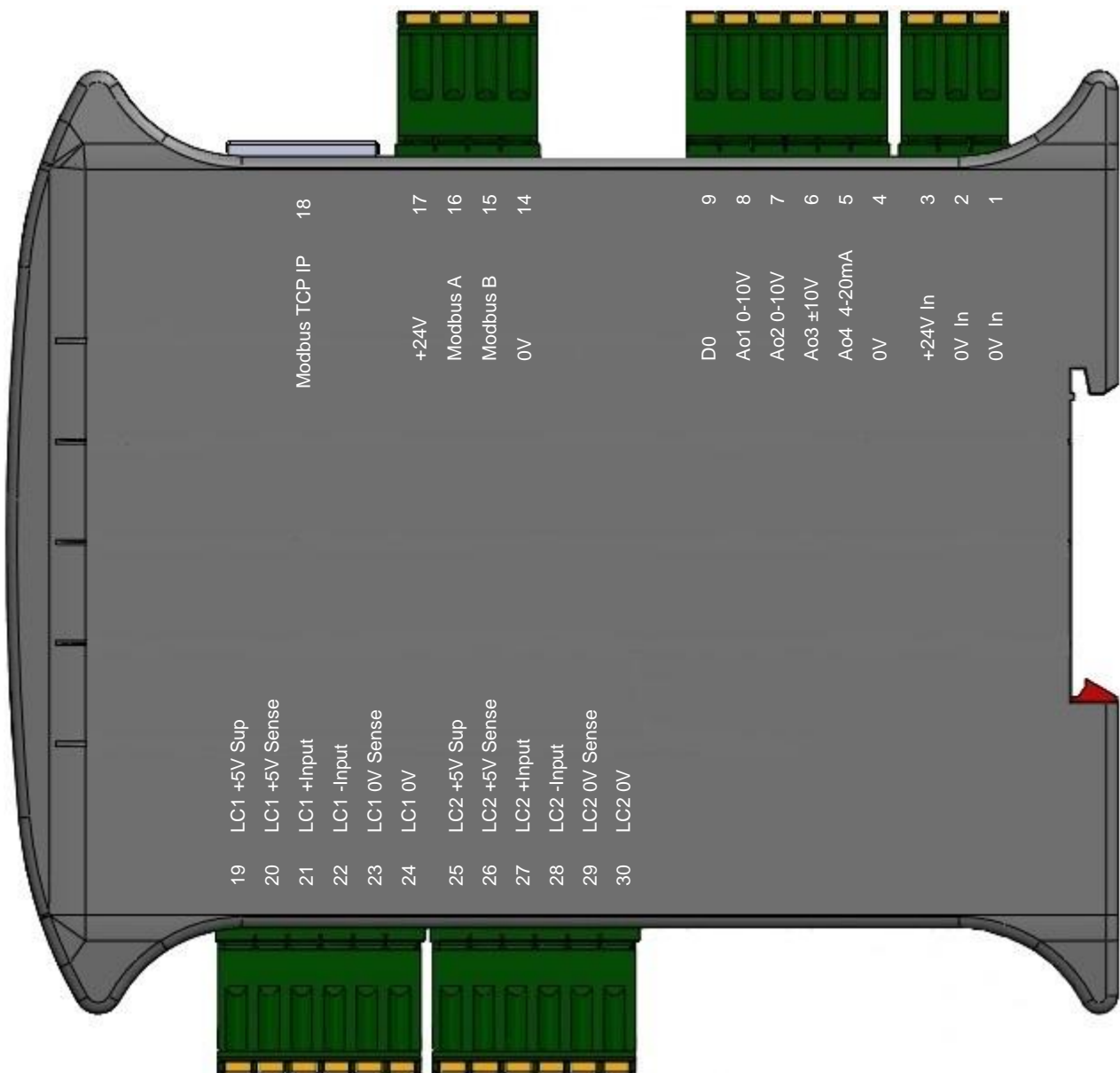

One Half Bridge Semiconductor (120 Ohm)

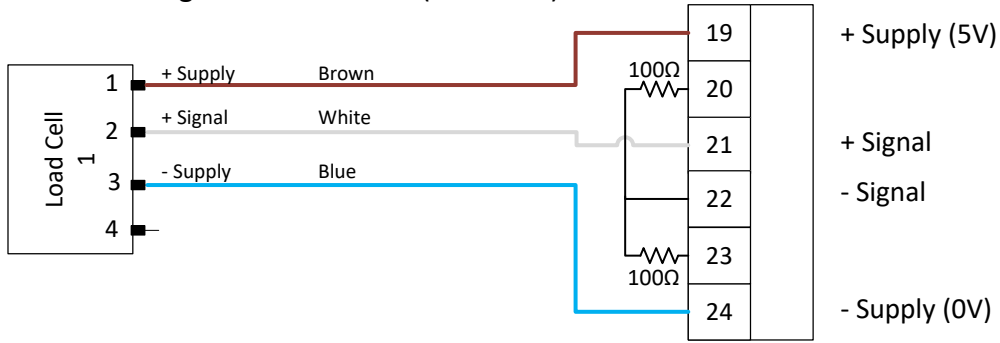

Two Half Bridge Semiconductor (120 Ohm)

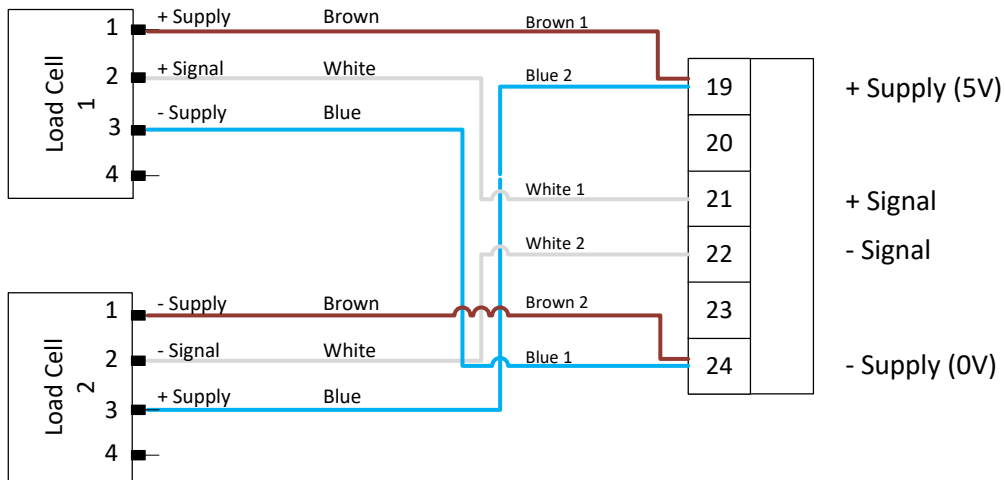

Two Half Bridge Semiconductor (120 Ohm)

Total-Left-Right

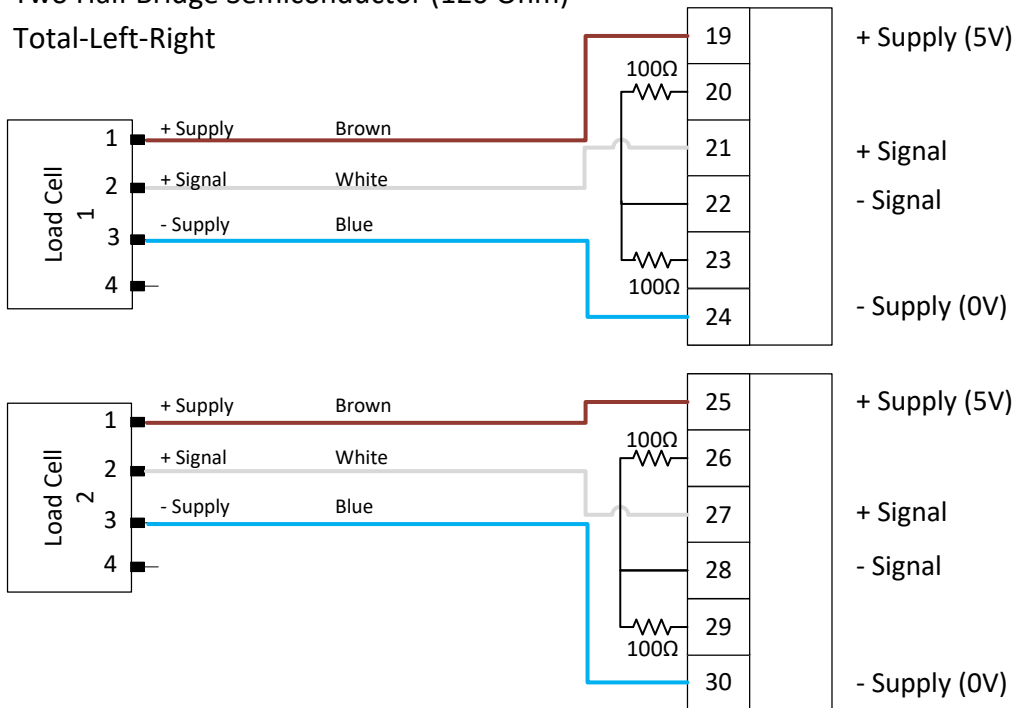

One Full Bridge Foil Gauge (350 Ohm)

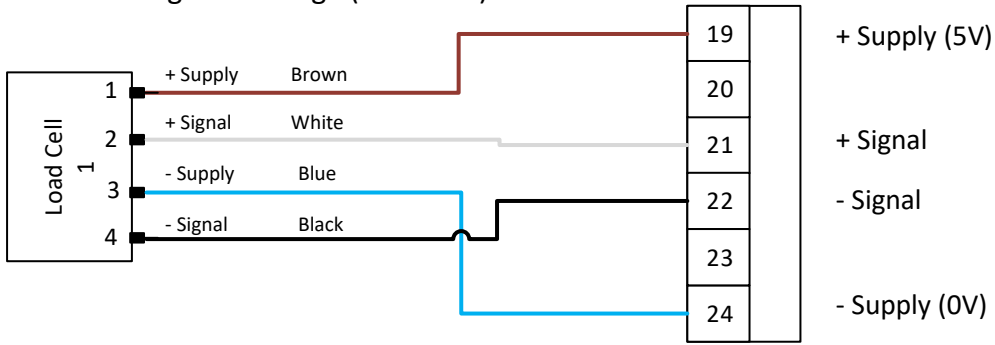

Two Full Bridge Foil Gauge (350 Ohm)

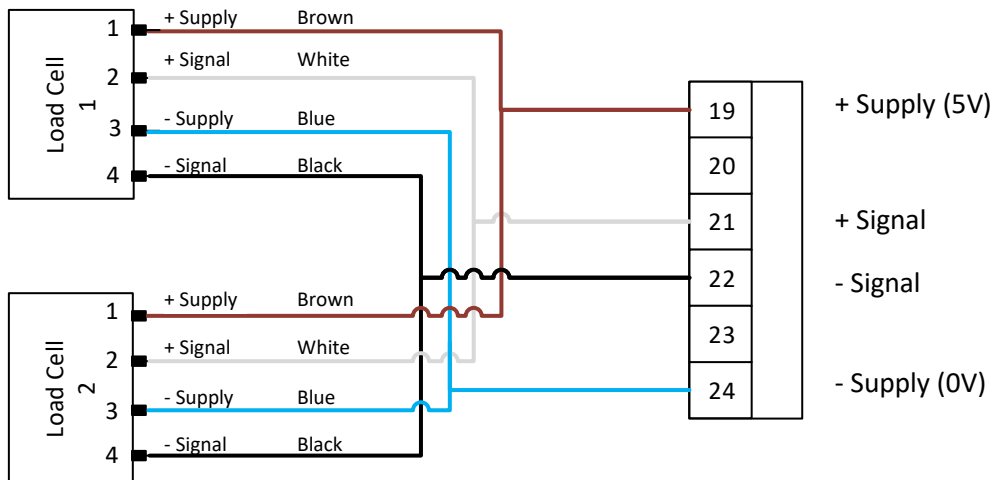

Two Full Bridge Foil Gauge (350 Ohm)

Total-Left-Right

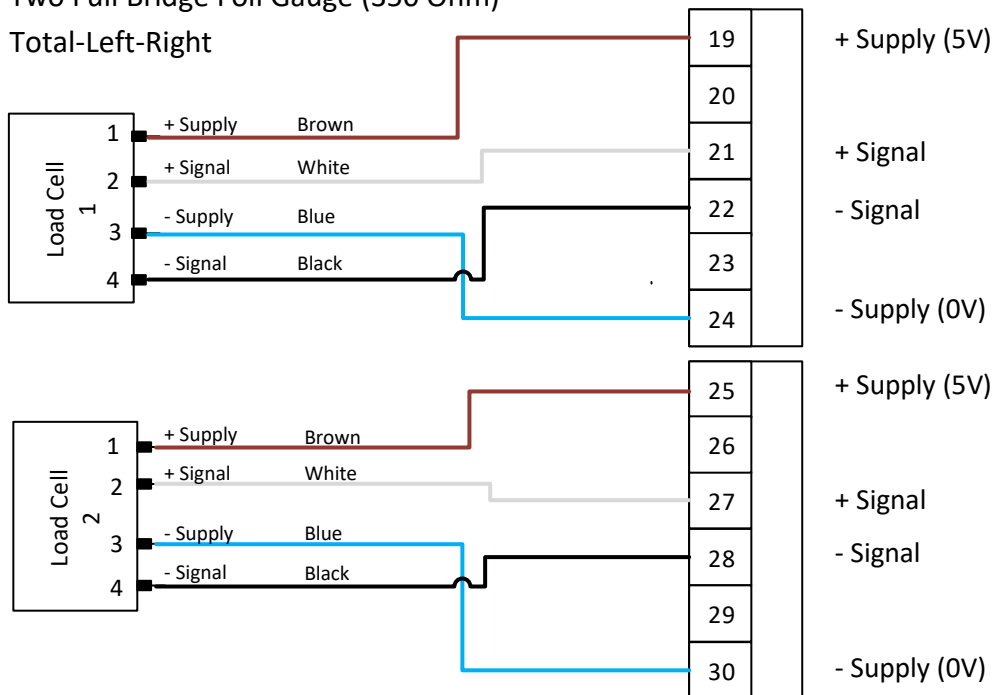

Setup and calibration menu:

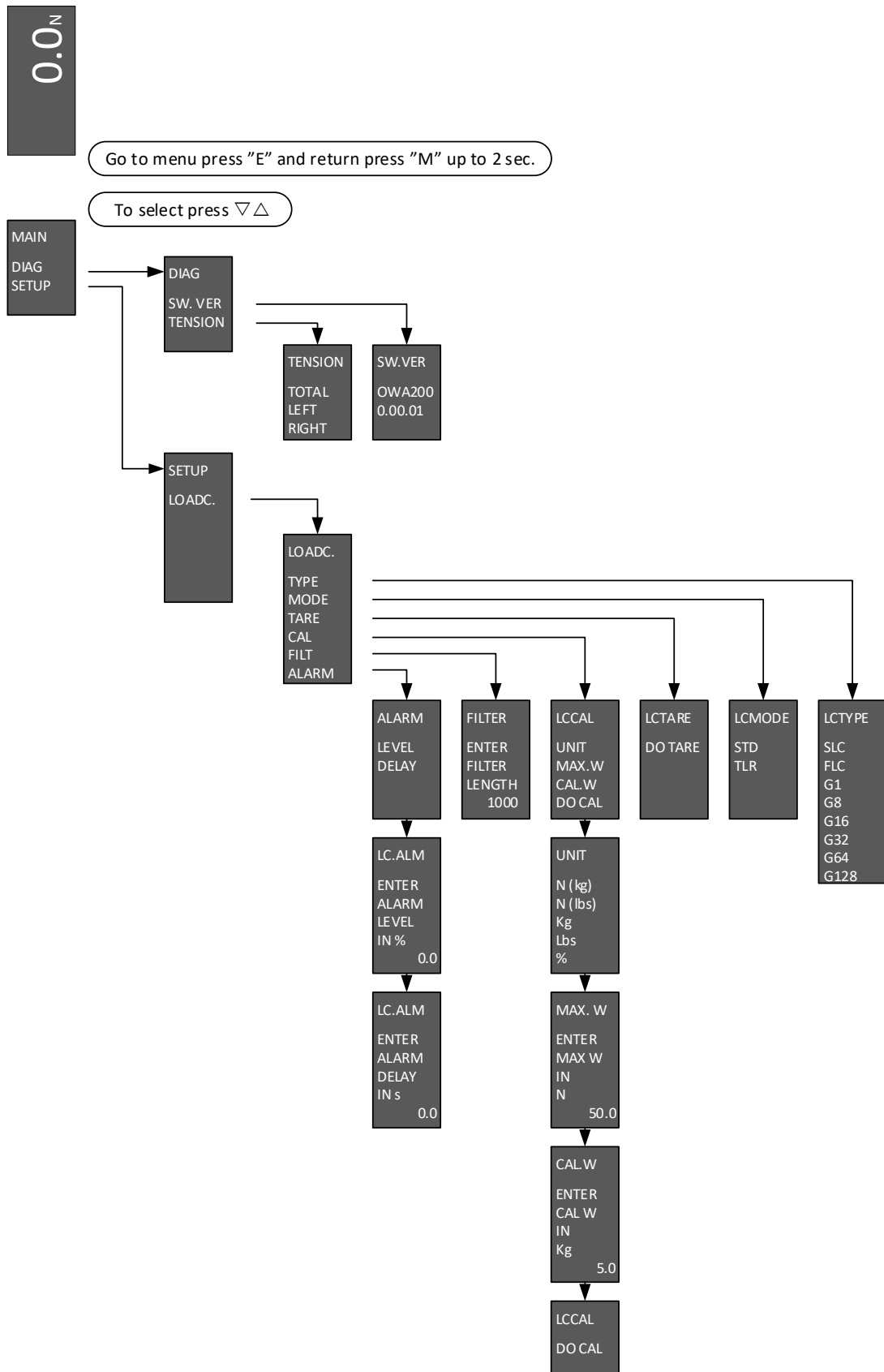

Glossary:

DIAG	:	Diagnostic
SW. VER	:	Software version; actual software version
LOADC.	:	Load Cell
LCTYPE	:	Load Cell type based on type of gauge
SLC	:	Strain gauge Load Cell 120 Ω semiconductor resistance
FLC	:	Foil gauge Load Cell 350 Ω resistance
G1-G128	:	Gain factor gives a selectable input range as follows: G1 : $\pm 2,5V$ G8 : ± 312 mV (Half Bridge 120 Ohm) G16 : ± 156 mV G32 : ± 78 mV G64 : ± 39 mV G128 : $\pm 19,5mV$ (Full Bridge 350 Ohm)
LCMODE	:	How the Load Cell is connected
STD	:	Standard is giving an average reading if two Load Cells are connected
TLR	:	Total-Left-Right is giving separated reading on each of two Load Cells connected, so the "Total" average reading, the Left side and Right side reading is available
TARE	:	Zero calibration without tension on the Load Cell
CAL	:	Calibration; with an know weight giving tension to the Load Cell
UNIT	:	The selected display and calibration weighing unit
N (kg)	:	Actual tension displayed in N and the physical calibration weight given in Kg.
N (lbs)	:	Actual tension displayed in N and the physical calibration weight given in lbs.
Kg	:	Actual tension displayed in Kg and the physical calibration weight given in Kg.
Lbs	:	Actual tension displayed in lbs and the physical calibration weight given in lbs.
%	:	Actual tension displayed in % and the physical calibration weight given in % of max tension
MAX. W	:	Max weight = Tension to be entered in selected display unit
CAL. W	:	Calibration weight to be entered in the selected calibration unit
FILT	:	Filter is selectable for analog output "Ao1", "Ao2" and "Ao4", all in one, output "Ao3" has no filter. The filter is based on a sampling frequency of 1 Khz and the filter is the average reading of the selected number of samples.
Alarm level	:	Level in % of max. tension when alarm is activated. Connected to output "D0" and preset value is 5%.
Alarm delay	:	Select the delay in seconds before "Alarm" is activated.

Quick calibration menu:

1. Make sure power is on = light in display

0.0_N

2. Go to menu press “E”

Go to menu press “E” and return press “M” up to 2 sec.

3. Select “SETUP”

To select press ▽△

MAIN
DIAG
SETUP

DIAG
SW. VER
TENSION

TENSION
TOTAL
LEFT
CAPAC.

SW. VER
OWA200
0.00.01

4. Select “LOADC.”

SETUP
LOADC.

LOADC.
TYPE
MODE
TARE
CAL
FILT
ALARM

5. Select “TARE”

6. Make sure there is no tension on the load cell and select then “DO TARE”

7. Go back to “LOADC.” select “CAL”

8. Select “UNIT”

9. Choose the wanted unit

10. Go back to “LCCAL” select “MAX. W”

11. Enter max. tension in given unit

12. Go back to “LCCAL”

13. Select “CAL. W”

14. Enter the actual calibration weight

15. Go back to “LCCAL” select “DO CAL”

16. Press “DO CAL”

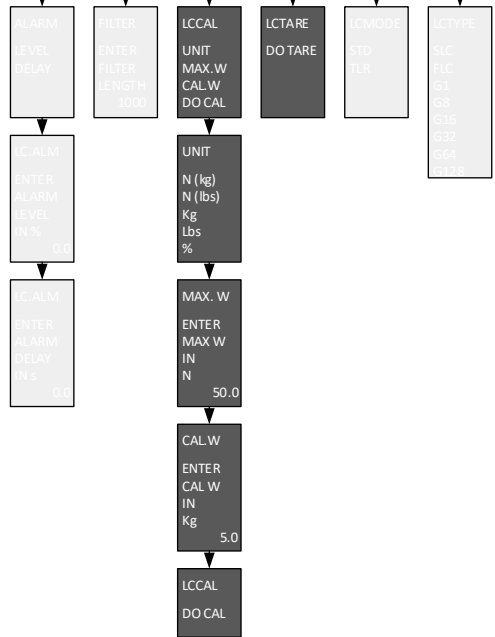

Notes:

Technical Features		OWA210	OWA220	OWA230
Mini USB port for programming		X	X	X
Total-Left-Right load measurement			X	X
Modbus RTU/RS485		X	X	X
Modbus TCP/IP Ethernet				X
Power supply				
Power supply	24VDC ±15%			
Measure range				
Measure range	±39mV to ±625mV			
Number of load cells Semiconductor				
Number of load cells Semiconductor	4 of 120 Ω Half bridge			
Number of load cells Strain gauge				
Number of load cells Strain gauge	4 of 350 Ω Full bridge			
Load cell's sensitivity				
Load cell's sensitivity	±1mV/V to ±100mV/V			
Conversion per second				
Conversion per second	1.000/s			
Response time				
Response time	1ms			
Analog output				
Analog output	2 of 0-10V, 1 of ±10V and 1 of 4-20mA			
Working temperature				
Working temperature	-20° to +60°C			