

OWECON OWL200 Idler Series Load Cell



The OWECON OWL200 Series dead Shaft Idler Roller Load Cells are dual beam tension load cells designed to maximize performance and reliability. The unique dual beam load cell design reduces load cell deflection by more than 66% compared to traditional load cell designs. Lower deflection means fewer tracking and steering problems on your machine and greater accuracy in the control.

Available in Two industry standard sizes and a wide variety of load ratings, the 200 Series Load Cells lead the industry in performance.

Advantages:

- ✓ Compact stainless steel body
- ✓ Twin Parallel Beam design ensuring high output at a minimum deflection
- ✓ Dual beam giving lowest possible deflection
- ✓ Choose between Semiconductor or Foil strain gauge
- ✓ Industry standard M12x1 connector. With turn able socket for L-plug
- ✓ Connector position available in 4 different positions relative to the load direction
- ✓ Overload ratings up to 10 times nominal load rating
- ✓ Flexible head automatically compensates for changes in axial load and shaft linear expansion



OWL210 and 220 are center bolt mount types of load cells. The connector M12x1 is always radially oriented.

OWL210F and 220F are center bolt mount types of load cells. The connector M12x1 is always radially oriented.

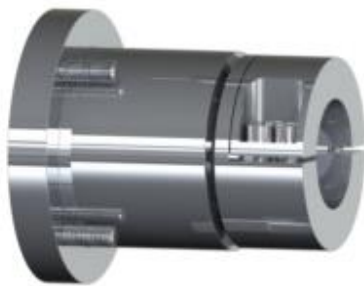
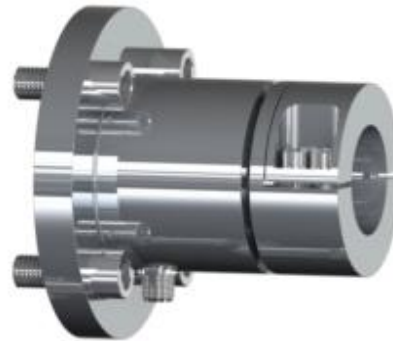

OWL210C and 220C are through-frame flange mount types of load cells. The connector M12x1 is always axially oriented.

OWL210C20 and 220C20 are recessed flange mount types of load cells. The connector M12x1 is as standard radially oriented and available as axially oriented. The flange position can be changed on customer request.



OWL210P and 220P are split pillow block types of load cells. The connector M12x1 is as standard radially oriented and available as axially oriented. With the connector axially oriented the load cell body can be moved in to the split pillow block.

Dimensions for OWL210 and OWL220

Center Bolt Mount Load Cells

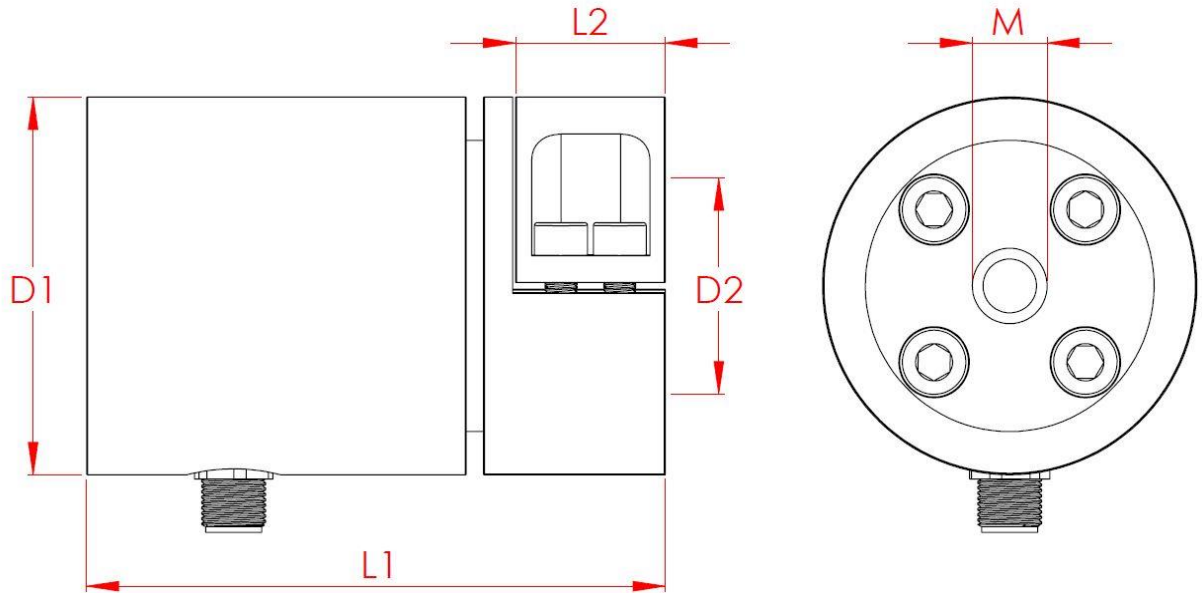

Dimension mm and Inches						
Type		D1	D2	L1	L2	M
OWL210	mm	50	25	75	13	M10 x12
	in	1.97	1.00*	2.95	0.51	M10 x 0.47
OWL220	mm	70	40	108	28	M16 x 15
	in	2.76	1.50*	4.25	1.10	M16 x 0.59

Load rating N and Lbs.											
OWL210	N	25N	50N	125N	250N	375N	500N	750N			
	Lbs.	5.6	11	28	56	84	112	168			
OWL220	N					375N	500N	750N	1.250N	2.500N	5.000N
	Lbs.					84	112	168	281	562	1.124

*To be specified on order

Dimensions for OWL210F and OWL220F

Surface Flange Mount Load Cells

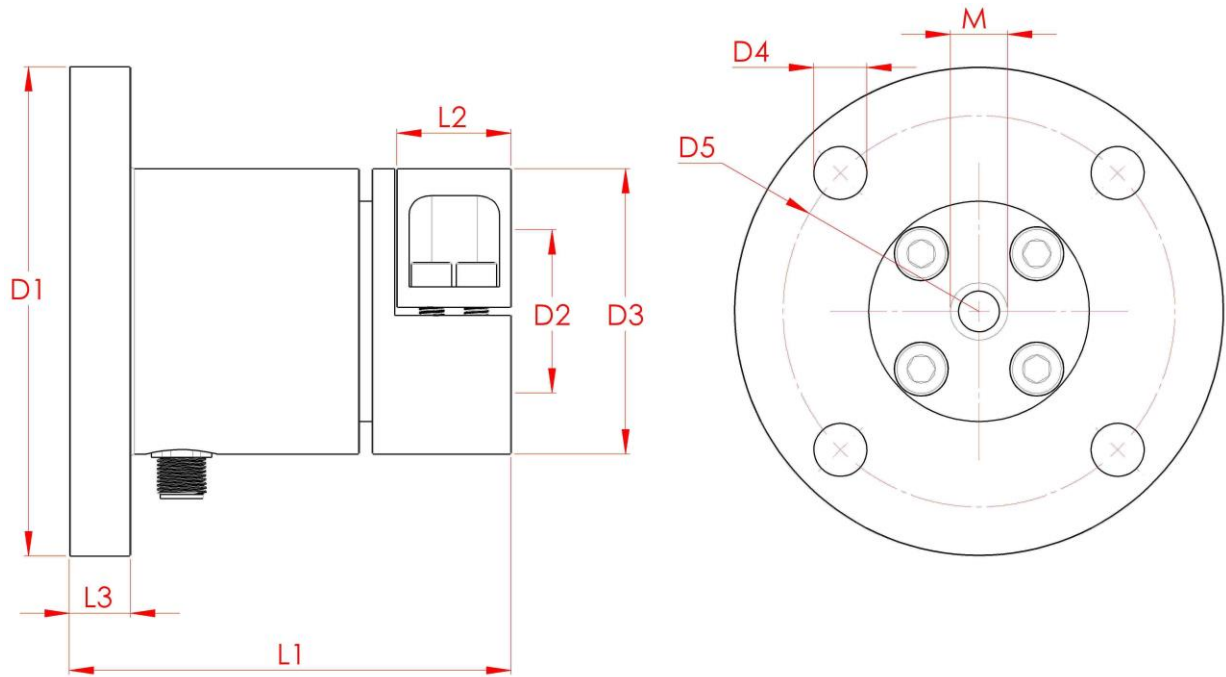

Dimension mm and Inches										
Type		D1	D2	D3	D4	D5	L1	L2	L3	M
OWL210F	mm	89	25	50	9	73	75	13	12	M10 x 12
	in	3.50	1.00*	1.97	0.35	2.87	2.95	0.51	0.47	M10 x 0.47
OWL220F	mm	120	40	70	13	96	108	28	15	M16 x 15
	in	4.72	1.50*	2.76	0.51	3.78	4.25	1.10	0.59	M16 x 0.59

Load rating N and Lbs.											
OWL210	N	25N	50N	125N	250N	375N	500N	750N			
	Lbs.	5.6	11	28	56	84	112	168			
OWL220	N					375N	500N	750N	1.250N	2.500N	5.000N
	Lbs.					84	112	168	281	562	1.124

*To be specified on order

Dimensions for OWL210C and OWL220C Through-frame Flange Mount Load Cells

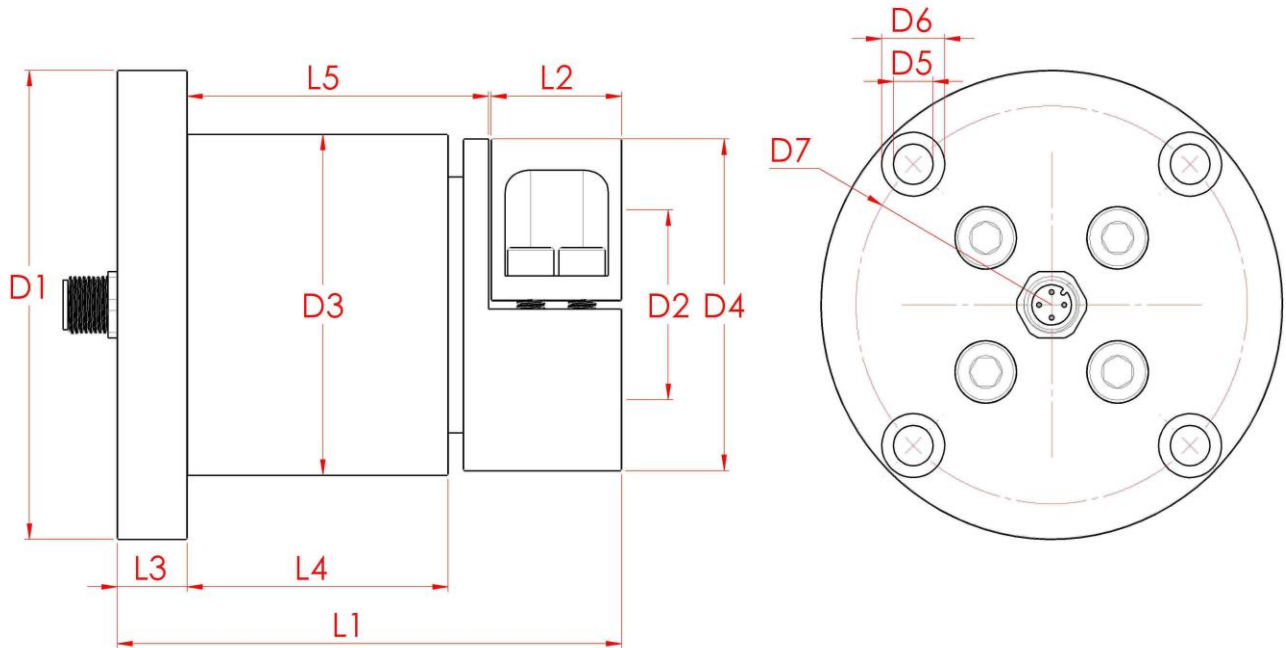

Dimension mm and Inches													
Type		D1	D2	D3	D4	D5	D6	D7	L1	L2	L3	L4	L5
OWL210C	mm	79	25	52	50	6,5	10,5	64	75	13	12	43	64,5
	in	3.11	1.00*	2.04	1.98	0.26	0.2"	2.52	2.95	0.51	0.47	1.69	2.54
OWL220C	mm	99	40	72	70	8,5	13,5	84	108	28	15	56	49,5
	in	3.90	1.50*	2.93	2.76	0.33	0.53	3.31	4.25	1.10	0.59	2.20	1.95

Load rating N and Lbs.											
OWL210	N	25N	50N	125N	250N	375N	500N	750N			
	Lbs.	5.6	11	28	56	84	112	168			
OWL220	N					375N	500N	750N	1.250N	2.500N	5.000N
	Lbs.					84	112	168	284	562	1.124

*To be specified on order

Dimensions for OWL210C20 and OWL220C20 Recessed Flange Mount Load Cells

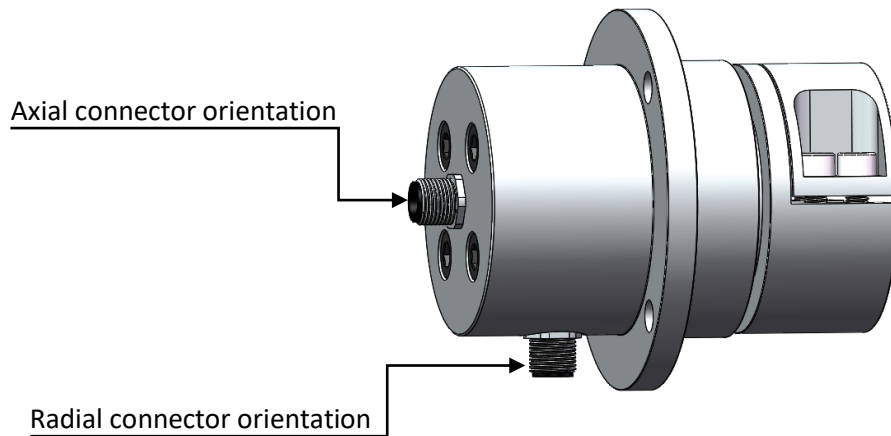
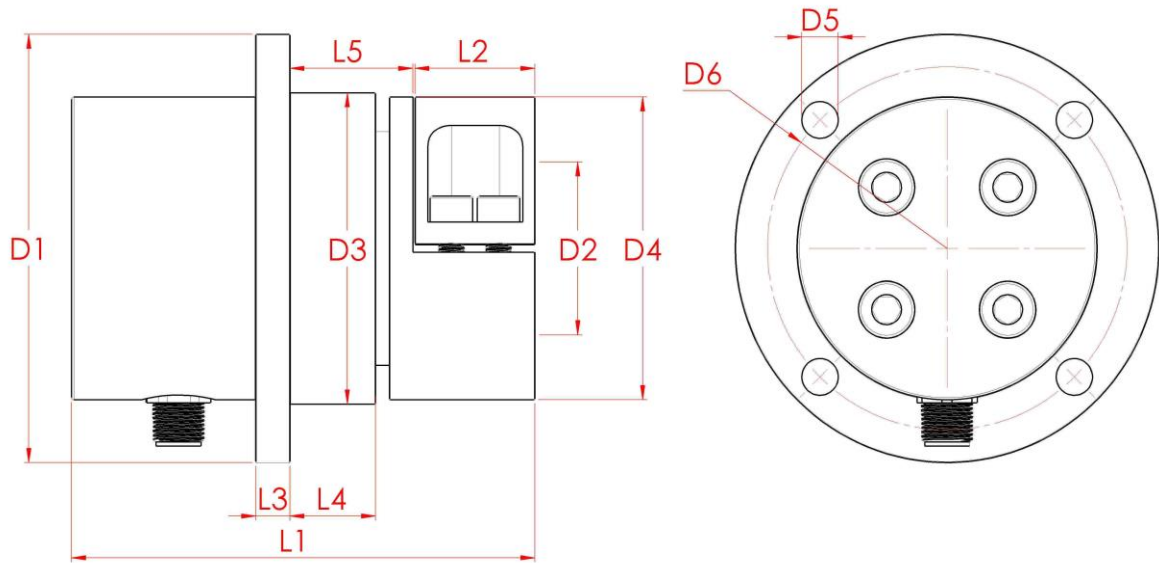

Dimension mm and Inches												
Type		D1	D2	D3	D4	D5	D6	L1	L2	L3	L4	L5
OWL210C20	mm	79	25	52	50	6,5	64	75	13	6	20	26,5
	in	3.11	1.00*	2.05	1.97	0.26	2.52	2.95	0.51	0.24	0.79	1.04
OWL220C20	mm	99	40	72	70	8,5	84	108	28	8	20	28,5
	in	3.90	1.50*	2.83	2.76	3.35	3.31	4.25	1.10	0.31	0.79	1.12

Load rating N and Lbs.											
OWL210	N	25N	50N	125N	250N	375N	500N	750N			
	Lbs.	5.6	11	28	56	84	112	168			
OWL220	N					375N	500N	750N	1.250N	2.500N	5.000N
	Lbs.					84	112	168	281	562	1.124

*To be specified on order

Dimensions for OWL210P and OWL220P Split Pillow Block Mount Load Cells

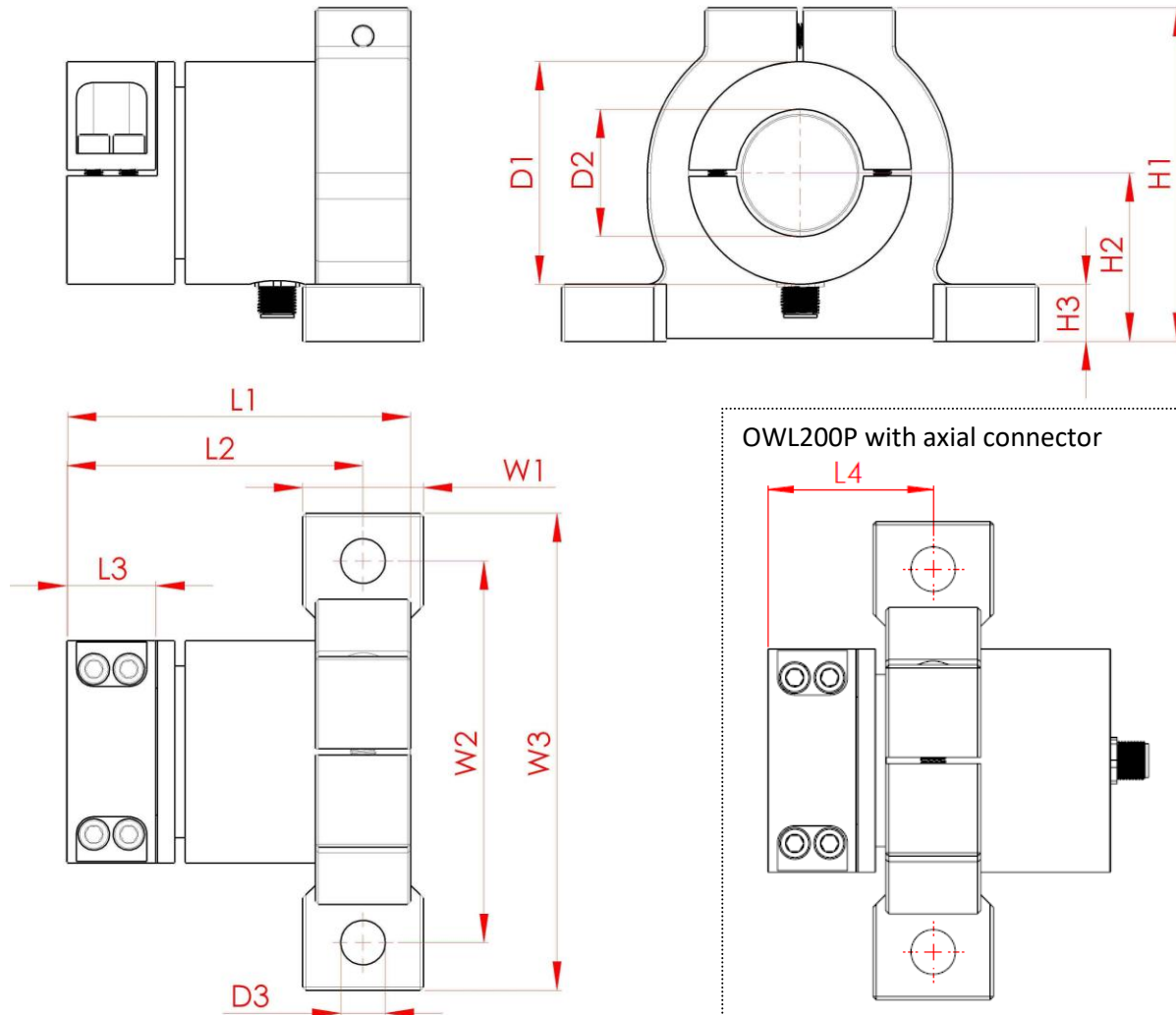

Dimension mm and Inches														
Type		D1	D2	D3	L1	L2	L3	L4	H1	H2	H3	W1	W2	W3
OWL210P	mm	50	25	9,5	75	65	13	30	83	37	12	20	94	116
	in	1.97	1.00*	0.37	2.95	2.56	0.51	1.18	3.27	1.46	0.47	0.79	3.70	4.57
OWL220P	mm	70	40	14	111	93	28	52	105	53	18	38	120	150
	in	2.76	1.50*	0.55	4.37	3.66	1.10	2.05	4.13	2.09	0.71	1.5	4.72	5.91

Load rating N and Lbs.											
OWL210	N	25N	50N	125N	250N	375N	500N	750N			
	Lbs.	5.6	11	28	56	84	112	168			
OWL220	N					375N	500N	750N	1.250N	2.500N	5.000N
	Lbs.					84	112	168	281	562	1.124

*To be specified on order

Calculating the sizing force for OWL200 Load Cell:

The correct Load Cell load rating for an application is determined by maximum web tension, web wrap angle around the roller, and mass of the roll.

The force $F_{(roll)}$ from the mass $m_{(roll)}$ of the roll, is determined as

$$F_{(roll)} = m_{(roll)} \times 9.82 \text{ (N)} \quad (9,82 = \text{mass acceleration } m/s^2)$$

The force $F_{(Load)}$, from the web tension $F_{(web)}$, is determined as

$$F_{(Load)} = 2 \times F_{(web)} \times \sin(X/2)$$

To determine the load cell size the 2 forces must be added together

Load direction upwards:

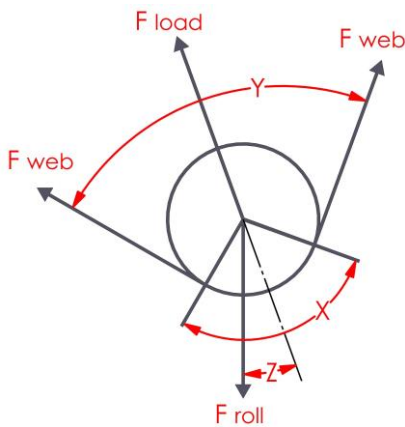

$$((\frac{1}{2} \times F_{(Load)} \times 1,5) - (\frac{1}{2} F_{(roll)} \times \cos(Z)))$$

Load direction downwards:

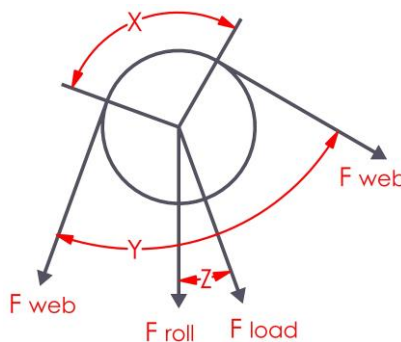

$$((\frac{1}{2} \times F_{(Load)} \times 1,5) + (\frac{1}{2} F_{(roll)} \times \cos(Z)))$$

Load direction Sideways:

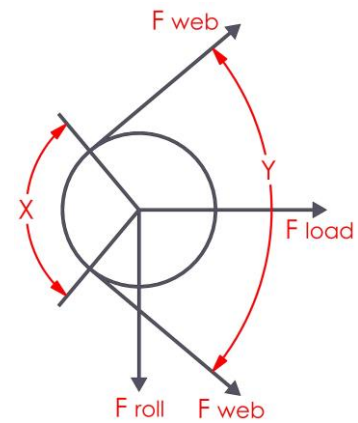

$$(\frac{1}{2} \times F_{(Load)} \times 1,5)$$

(1,5 = Safety factor)

Note:

The minimum load cell size has to be $> \frac{1}{2} \times F_{(roll)}$

$m_{(roll)}$ = The mass of the roller in kg, $F_{(web)}$ = Maximum web tension, Z = Angle between $F_{(Load)}$ and vertical, X = Web wrap angle = $180^\circ - Y^\circ$

Specifications half bridge:

Max operating force relative to F_n	150%
Force limit relative to F_n	200%
Strain gauge resistance.....	80 to 120 ohm
Strain gauge configuration.....	half bridge
Supply.....	5VDC
Nominal output.....	50mV/V
Combined error relative to F_n	< 0.5%
Temperature coefficient.....	<0.4% / 10K
Operating temperature range.....	(-4 to 185° F) -20 to +85° C
Deflection at F_n	(< 0.0039") < 0.1 mm

Specifications full bridge:

.....	150%
.....	200%
Foil gauge resistance.....	350 ohm
Foil gauge configuration.....	full bridge
.....	10VDC
.....	1mV/V
.....	< 0.5%
.....	<0.4% / 10K
.....	(-4 to 185° F) -20 to +85° C
.....	(< 0.0039") < 0.1 mm

Semiconductor Strain Gauge Half Bridge:

M12 - 4 pin male, Code A, IEC61076-2-101

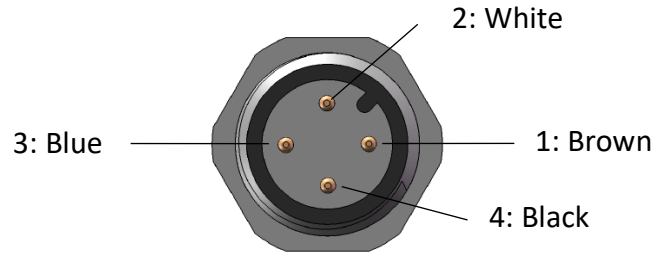

One Half Bridge Semiconductor (120 Ohm)

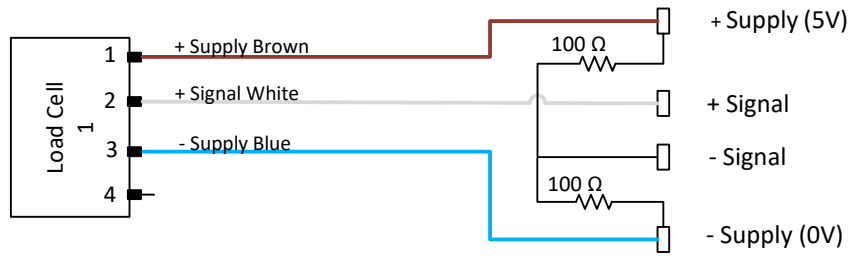

Two Half Bridge Semiconductors (120 Ohm)

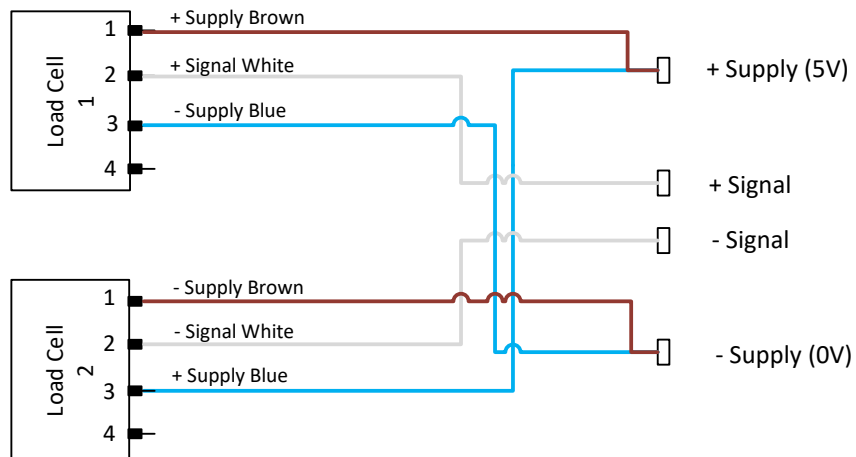

**Two Half Bridge Semiconductors (120 Ohm)
For Total-Left-Right**

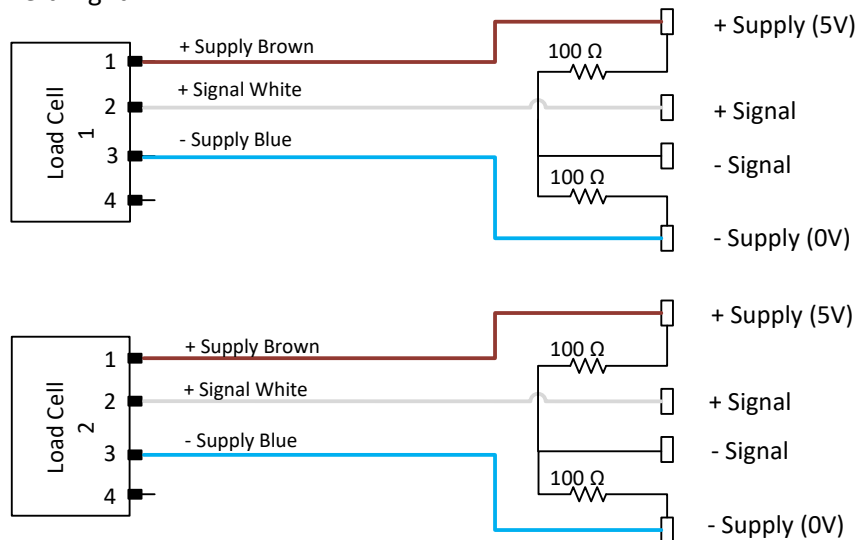

Foil Gauge Full Bridge:

M12 - 4 pin male, Code A, IEC61076-2-101

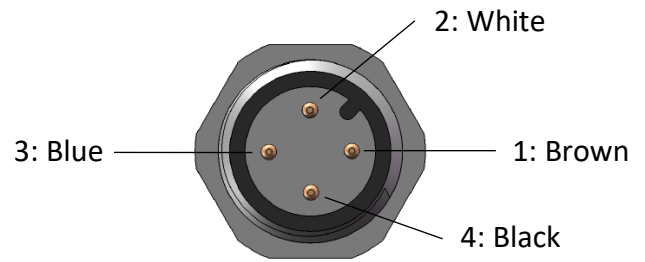

One Full Bridge Foil Gauge (350 Ohm)



Two Full Bridge Foil Gauge (350 Ohm)

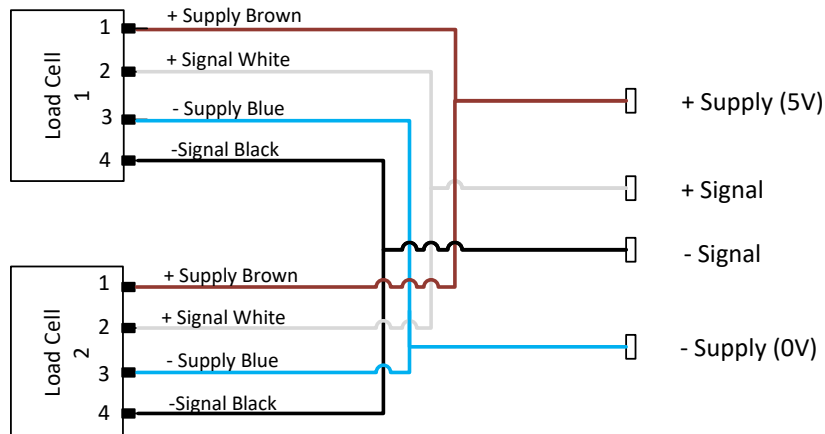

Two Full Bridge Foil Gauge (350 Ohm)

For Total-Left-Right

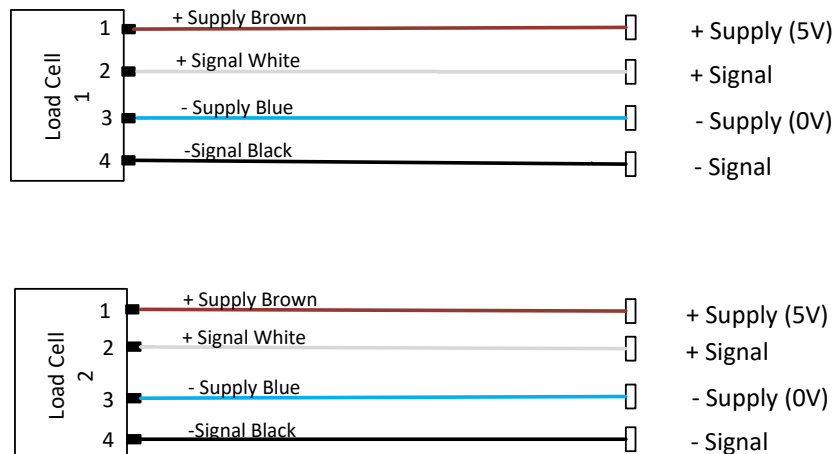

Connector orientation and position:

All Load Cells comes with an M12x1 standard connector. The connector orientation and position is available in different alternative version depending on the type of Load Cell and if not mentioned on order the following standards will be used.

Connector orientation:

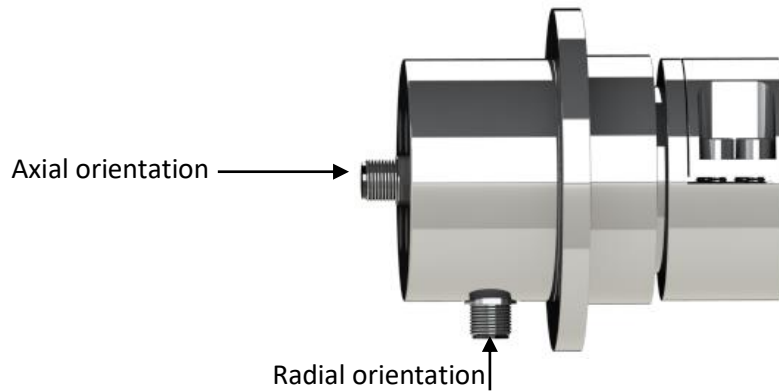

Type of load Cell	Standard orientation	Alternative orientation
OWL210 and OWL220	Radial	NA
OWL210F and OWL220F	Radial	NA
OWL210C and OWL220C	Axial	NA
OWL210C20 and OWL220C20	Radial	Axial
OWL210P and OWL220P	Radial	Axial

Connector position and load direction:

If the Load Cell comes with a radial oriented connector there are 4 possible mounting positions for the connector named as 3:00 o'clock, 6:00 o'clock, 9:00 o'clock and 12:00 o'clock, please see illustration. The 3:00 o'clock and 9:00 o'clock comes as pair for the connectors to point in same direction, when load cells are mounted pointing towards each other. As standard the Load Cells comes with the 6:00 o'clock connector position and load direction will be the same as shown on the label. Any other connector position has to be specified on order.

