

## OWECON OWA120/130 Loadcell Amplifier



The **OWECON OWA120/130 series amplifier** is a universal loadcell amplifier covering all types of standard loadcells in paper, foil and converting industry.

- Working Range: 1mV/V to 50mV/V loadcell signal
- Handles applications of: Constant Voltage or Constant Current – Bridge supply
- Cost / Performance effective
- Available in 24VDC and 110-240VAC models
- Extra flat, DIN Rail mount w./ metal foot catch

### Applications:

The OWECON OWA amplifier and OWI Indicator are used with OWECON - or third party loadcells to indicate web tension on all types of web-process and converting machines. The output can be used to drive a tension meter. For processing, the output can be interfaced to a PLC, PC or motor-drive

## Mechanical specifications

Outline, mechanical dimensions:

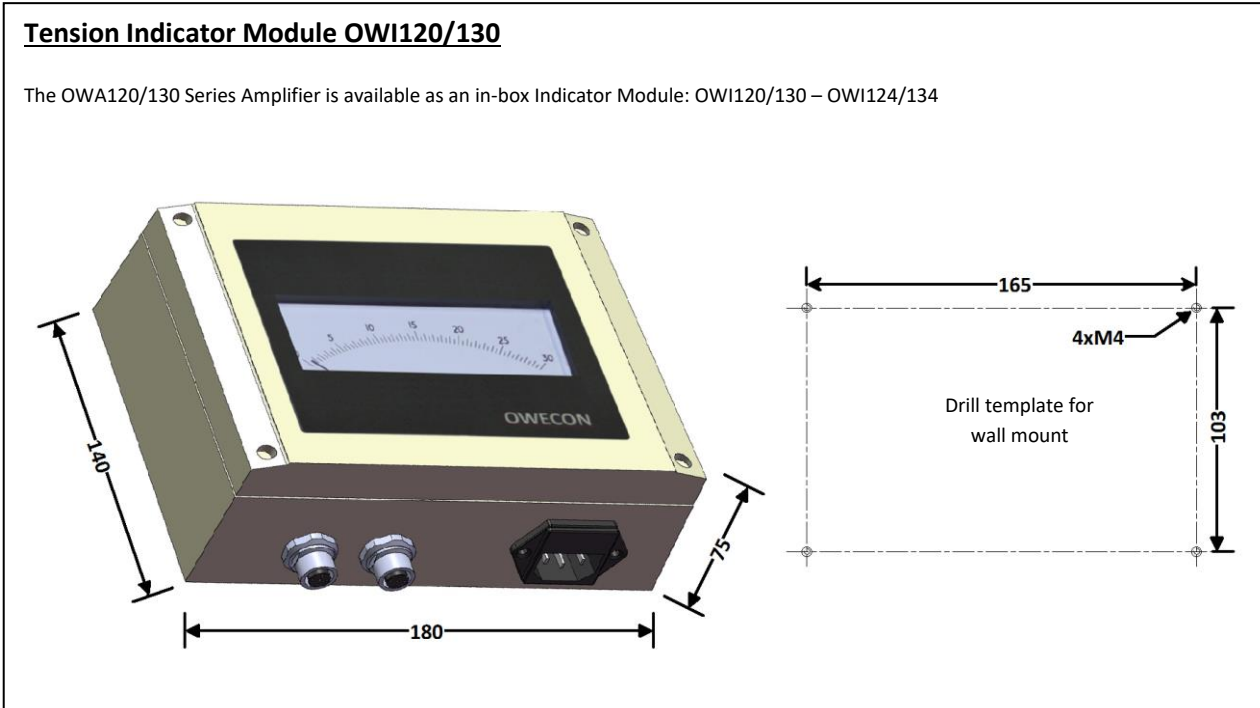
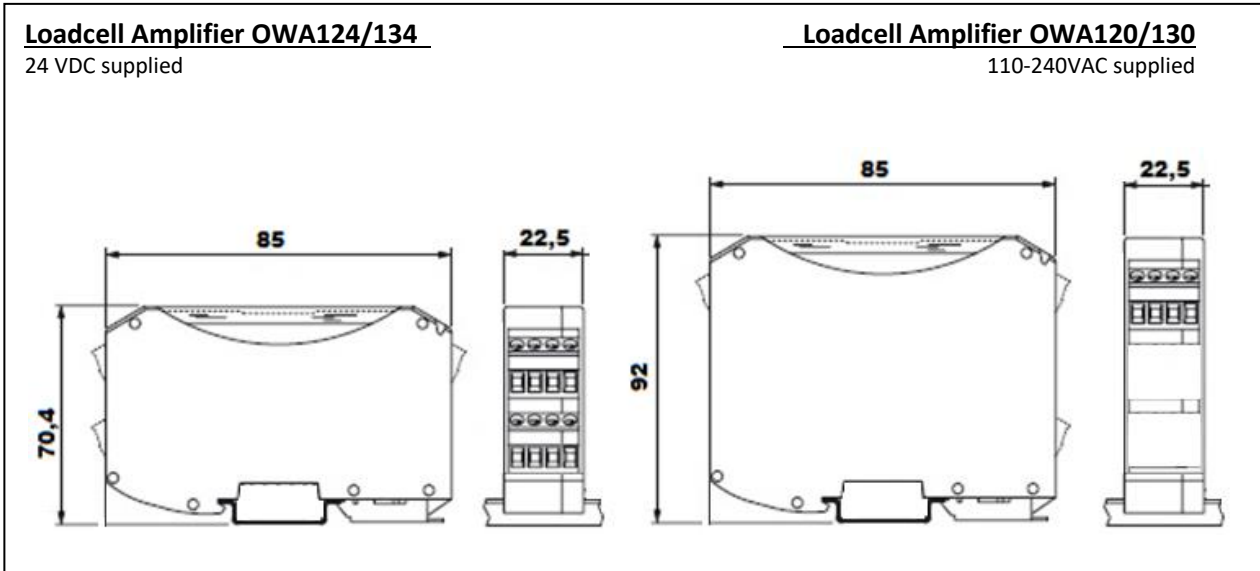

## Electrical

### Loadcell Installation

The OWA120/130 Series Amplifier is compatible to all types of loadcells in the market.

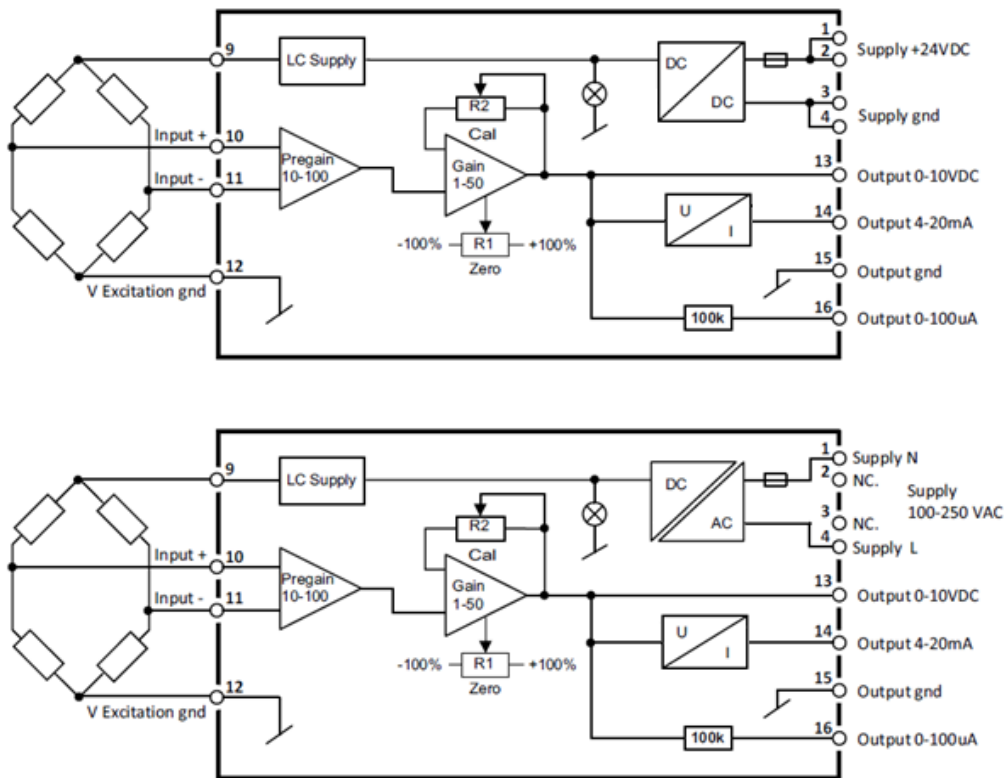

### Electrical specifications:

Supply Voltage OWA/OWI124/134.....24VDC +/-15%  
 Supply Voltage OWA/OWI120/130.....90-264VAC  
 Overvoltage Category .....3kVAC (Class II)  
 Maximum Power Consumption .....4 W  
 Maximum Supply Fuse Size .....1 A  
 Load Cell Input .....± 1-50 mVDC  
 Input Impedance .....100 kΩ  
 Load Cell Supply .....±2.50 VDC ±1%  
 Zero Range Adjustment ..... 100% of Load Cell Rating (± 50mVDC)  
 Gain Adjustment .....10 to 5000 depending on type  
 Accuracy ..... Better Than 1%  
 Meter Output.....0 to 100 μA  
 Process Output .....4 to 20 mA and 0 to 10VDC  
 Process Output Maximum Load (Current) .....≤ 500 Ω  
 Process Output Maximum Load (Voltage) .....≥ 5000 Ω

Standard Scales OWI Indicator.....0-100, others on request  
 Connections .....Removable Terminal Blocks  
 Mounting Bracket .....DIN Rail  
 Mounting Orientation .....Not Critical  
 Ambient Temperature Range: Operating .....-10°C to 50°C  
 Ambient Temperature Range: Storage .....-10°C to 80°C  
 Humidity .....<95% Non-Condensing  
 Degree of Protection .....IP54 (IEC 529)  
 EMC-Immunity .....EN 50082-2 Industry  
 EMC-Emission .....EN 50081-1 Trade and Light Industry  
 Installation Environment (Pollution Degree) .....2  
 Weight OWA .....0.10 /0.12 kg  
 Weight OWI .....1.5 kg  
 Size OWA 124/134( WxDxH ).....22,5mm x 70,4mm x 85mm  
 Size OWA 120/130( WxDxH ).....22,5mm x 92mm x 85mm

**Calibration:**

For the calibration procedure you need a small screwdriver, a multimeter, a rope, and a calibration weight. Choose what the maximum working web tension will be and find an appropriate calibration weight. For an optimum weight calibration, the weight should be at least 25% of the maximum tension. Before calibration make sure that the sensing roller is mounted correctly.

The calibration step are as follows:

1. Use a multimeter, VDC range, connected between terminals 13 (+) and 15 (-).  
(For the OWI, read the present meter).
2. Make sure there is no weight on the sensing roller. Adjust the "ZERO" screw until 0 V is measured or read out on the meter.
3. Thread a rope around the center of the sensing roller, let it pass at least one roller before and one after the sensing roller.
4. Attach a weight of known value to the rope, at least 25% of the chosen maximum web tension.
5. Adjust on the "GAIN" screw until the multimeter shows a value calculated with the following formula:

$$V = (\text{Cal. Weight} / \text{Cal. Max. tension}) \times 10\text{Volts}$$

Or for the OWI, the meter reads the calibration weight.

- A negative reading indicates that the loadcell signals are reversed. Switch the wires between terminals 10 and 11.
- Remove the weight and check that outputs return to 0. If not, repeat procedure steps from top.

Loosen the rope when Zero calibration:

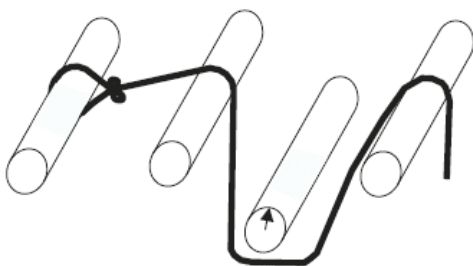

Tighten the rope with the calibration weight when weight calibration:

